

FLEXOL TABLE





for overhead projectors, height adjustable

Practical table for overhead projectors, projectors, and episcope, tubular steel structure, epoxy powder coated, steel base with pivoting wheels equipped with blocking device, support in rubber boarded with rounded profile, adjustable height and knob blocking system. FLEXOL table, has been designed for video-projectors, offers the possibility to adjust the inclination of the support shelf up to 15°.

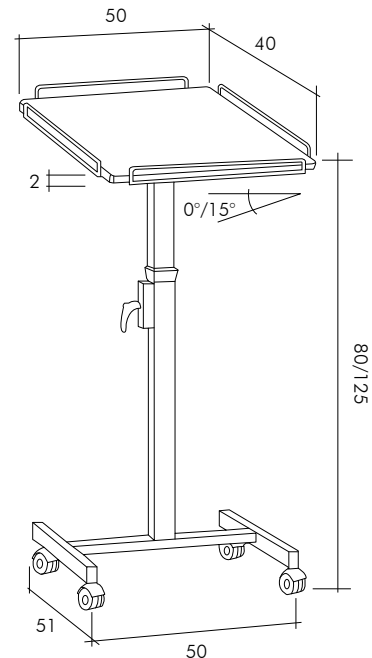
Technical features

- **Steel tubular structure**, section 50x50 / 45x45 / 50x25 mm with telescopic, **very sturdy** central column
- **Excellent stability** thanks to the low base's barycentre, total **absence of vibrations**
- **Manual height adjustment**, progressively, from 80 cm to 125 cm, blocking by means of black moulded **plastic**
- **Epoxy powder coating** in silver grey colour RAL 6005
- **Bi-laminate, anti-slip, supporting surface**, 20 mm thickness, format 50x40 cm, light grey colour RAL 7035, **black rubber boarded** with rounded profile; anti-fall perimetrical borders, made of steel wire silver grey colour RAL 6005, tilting adjustment from 0° to 15° by means of moulded plastic knob positioned under the shelf.
- **4-caster wheels**, Ø 50 mm, equipped with **blocking device**; support, roller bearing, central structure and rotary part in polypropylene, wheel load capacity 35 Kg
- **Total maximum load capacity 30 Kg**, at 80 cm; **20 Kg** capacity at 125 cm



			
609025	"FLEXOL" TABLE	50x40x80/130	51x66x14
Size in cm, weights expressed in kilograms, diagonal expressed in inches (")			